

MAV 2008

MAV 2108

MAV 2208

Standard Series

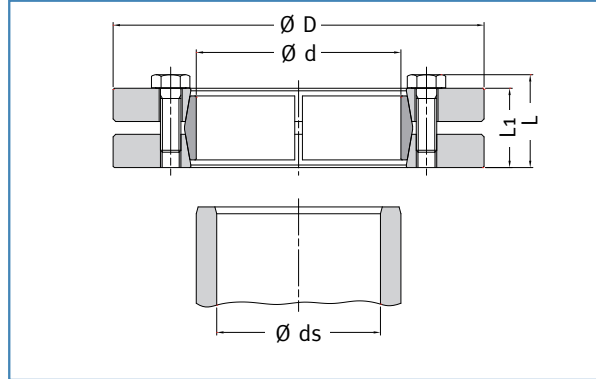
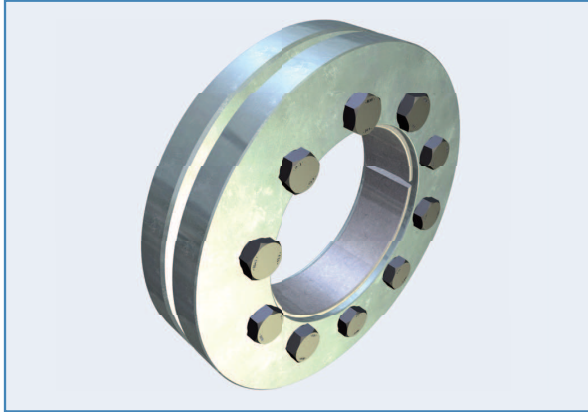

Example of order: MAV 2008 68 x 115

Composition

- Slotted inner ring
- Front outer ring
- Rear outer ring
- Set of hexagonal head cap screws, grade 10.9 (size <math>< \text{M6}</math> of grade 8.8)

Features

- External locking device for hollow shaft (hub) - shaft connection
- Three-part design
- Self-releasing tapers, greased with MoS₂ ($\mu = 0.05$)
- Screws greased with MoS₂ ($\mu = 0.10$)
- Zinc plated outer rings
- O-Ring between outer rings from size $d = 140$ mm and above
- MAV 2008: standard series, medium capacity
- MAV 2108: light series, low capacity
- MAV 2208: heavy series, high capacity
- SPLIT and HALF HC and HT versions also available (for HALF versions, performances are reduced of 50%)
- Tolerances of shaft and hub bore: see table
- Tolerance of hub outer diameter: h8
- Surface finish of shaft and hub $Ra < 3.2 \mu\text{m}$
- Shaft - hub bore contact surface grease-free and dry ($\mu = 0.15$)

Shaft Diameter ds		ISO Tollerances	Max Clearance
from	to		mm
6	10	H6 - j6	0,011
11	18		0,014
19	30		0,017
31	50	H6 - h6	0,032
51	80	H6 - g6	0,048
81	120	H7 - g6	0,069
121	180		0,079
181	250		0,09
251	315		0,101
316	400		0,111
401	500		0,123

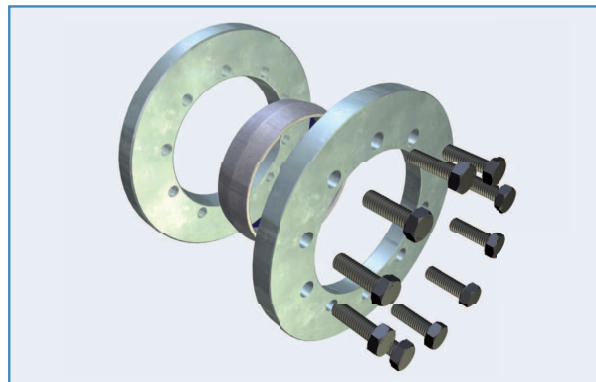

DIMENSIONS										SCREWS			FEATURES				WEIGHT kg
ds mm	d mm	x	D mm	L mm	L1 mm	L2 mm	L3 mm	lv mm	a x 45° mm	n.	size	Ma Nm	Mt Nm	Fax kN	Ps MPa	Ph MPa	
10													36	7	154	335	
11	14	x	38	18,5	15,0	6,0	8,7	25	1,2	3	M 5	4	54	10	191	335	0,10
12													82	14	243	335	
13	16	x	41	20,5	17,0	7,0	9,7	27	1,2	3	M 5	4	38	6	93	244	0,10
14													65	10	136	244	
14													97	14	175	244	
15	18	x	44	20,5	17,0	7,0	9,7	29	1,2	4	M 5	4	96	14	172	289	0,14
16													130	17	205	289	
16													170	21	235	289	
17	20	x	46	20,5	17,0	7,0	9,7	32	1,2	5	M 5	4	130	17	205	325	0,15
19													170	21	232	325	
19													210	25	258	325	
20	24	x	50	21,5	18,0	7,8	11,5	36	2,1	6	M 5	4	220	24	189	279	0,19
21													280	28	209	279	
24													330	32	228	279	
25	30	x	60	23,5	20,0	8,5	12,5	44	2,1	7	M 5	4	350	29	159	228	0,29
26													400	32	172	228	
28													470	36	184	228	
30	36	x	72	26,0	22,0	9,5	13,5	52	2,1	5	M 6	12	770	55	232	297	0,47
31													960	64	250	297	
34													980	63	240	297	
35	44	x	80	28,0	24,0	10,5	14,5	61	2,1	7	M 6	12	1.200	72	225	306	0,59
36													1.400	77	235	306	
38													1.500	83	244	306	
40	50	x	90	31,0	27,0	11,5	16,0	70	2,1	8	M 6	12	1.500	80	204	280	0,81
42													1.800	91	219	280	
42													2.100	101	232	280	
45	55	x	100	33,0	29,0	12,5	17,0	75	2,9	8	M 6	12	1.700	80	176	243	1,1
48													2.100	94	193	243	
48													2.600	110	210	243	
50	62	x	110	33,0	29,0	12,5	17,0	86	2,9	10	M 6	12	2.700	110	213	270	1,3
52													3.000	120	222	270	
50													3.200	120	218	270	
55	68	x	115	33,0	29,0	12,5	17,0	86	2,9	10	M 6	12	2.500	100	184	246	1,3
60													3.100	110	188	246	
													4.100	140	212	246	

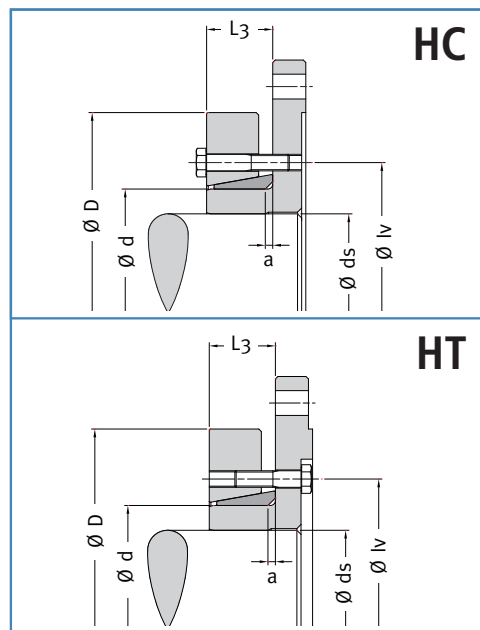
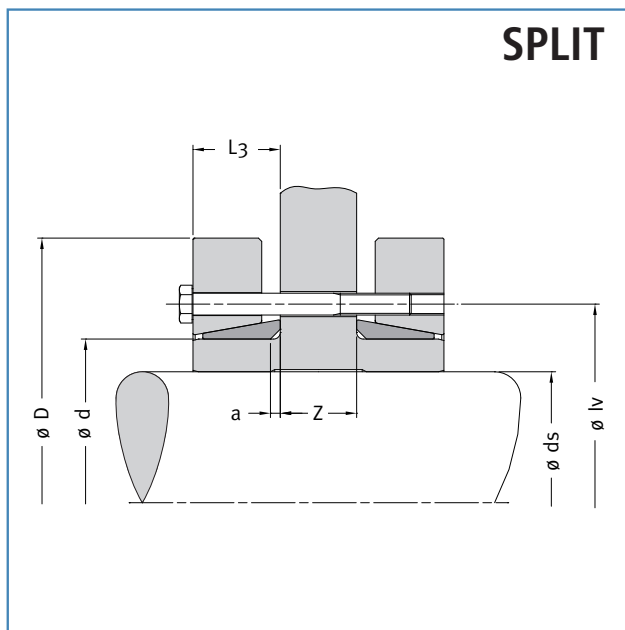

MAV 2008

Standard Series

DIMENSIONS										SCREWS			FEATURES				WEIGHT kg
ds mm	d mm	x	D mm	L mm	L1 mm	L2 mm	L3 mm	lv mm	a x 45° mm	n.	size	Ma Nm	Mt Nm	Fax kN	Ps MPa	Ph MPa	
55													3.500	130	199	276	
60	75	x	138	36,3	31,0	13,0	20,5	100	3,7	7	M 8	30	4.700	160	221	276	2,2
65													6.000	180	241	276	
60													4.100	140	192	259	
65	80	x	145	36,3	31,0	13,0	20,5	100	4,0	7	M 8	30	5.200	160	211	259	2,4
70													6.600	190	228	259	
60													5.400	180	213	290	
65	85	x	155	43,3	38,0	16,5	24,0	114	4,0	10	M 8	30	6.900	210	231	290	3,4
70													8.600	250	248	290	
65													6.200	190	206	274	
70	90	x	155	43,3	38,0	16,5	24,0	114	4,0	10	M 8	30	7.700	220	222	274	3,3
75													9.400	250	236	274	
65													6.800	210	200	274	
70	95	x	170	48,3	43,0	19,0	26,5	124	4,0	12	M 8	30	8.400	240	215	274	4,6
75													10.300	270	228	274	
70													7.600	220	194	261	
75	100	x	170	48,3	43,0	19,0	26,5	124	4,0	12	M 8	30	9.300	250	207	261	4,4
80													11.300	280	220	261	
70													8.100	230	180	253	
75	105	x	185	55,4	49,0	21,5	29,5	136	4,0	9	M 10	59	10.000	270	193	253	6,2
80													12.100	300	205	253	
75													9.100	240	176	242	
80	110	x	185	55,4	49,0	21,5	29,5	136	4,0	9	M 10	59	11.000	280	188	242	5,9
85													12.200	290	183	242	
80													11.500	290	191	250	
85	115	x	200	56,4	50,0	22,0	30,0	150	4,0	10	M 10	59	12.600	300	185	250	7,2
90													15.100	340	198	250	
85													11.400	270	168	240	
90	120	x	200	56,4	50,0	22,0	30,0	150	4,0	10	M 10	59	13.800	310	180	240	7,0
95													16.300	340	192	240	
85													13.300	310	186	263	
90	125	x	215	59,4	53,0	23,0	31,5	160	4,0	12	M 10	59	15.800	350	198	263	8,7
95													18.600	390	209	263	
90													14.600	320	182	253	
95	130	x	215	59,4	53,0	23,0	31,5	160	4,0	12	M 10	59	17.200	360	193	253	8,4
100													20.100	400	203	253	
95													18.600	390	190	259	
100	140	x	230	65,5	58,0	25,0	34,0	175	6,0	10	M 12	100	21.600	430	199	259	10
105													24.900	470	208	259	
105													25.400	480	195	259	
110	155	x	263	69,5	62,0	26,0	36,0	192	6,0	12	M 12	100	29.000	530	203	259	15
115													32.800	570	211	259	
115													38.900	680	223	278	
120	165	x	290	78,0	68,0	29,0	39,0	210	5,0	8	M 16	250	43.600	730	230	278	21
125													47.600	760	231	278	
125													42.900	690	208	262	
130	175	x	300	78,0	68,0	29,0	39,0	220	6,0	8	M 16	250	47.800	740	215	262	21
135													53.100	790	221	262	
135													60.000	890	197	244	
140	185	x	330	95,0	85,0	36,0	47,5	236	6,0	10	M 16	250	66.400	950	202	244	34
145													73.100	1.000	208	244	
140													75.600	1.100	231	278	
150	195	x	350	95,0	85,0	36,0	47,5	246	6,0	12	M 16	250	90.600	1.200	241	278	38
155													98.700	1.300	245	278	
150													87.000	1.200	231	271	
155	200	x	350	95,0	85,0	36,0	47,5	246	6,0	12	M 16	250	94.800	1.200	236	271	37
160													103.000	1.300	240	271	
160													110.000	1.400	208	249	
165	220	x	370	114,0	104,0	45,0	59,5	270	8,0	15	M 16	250	120.000	1.500	212	249	50
170													129.000	1.500	216	249	
170													146.000	1.700	233	273	
180	240	x	405	120,5	108,0	47,0	61,5	295	8,0	12	M 20	490	168.000	1.900	239	273	63
190													190.000	2.000	243	273	

DIMENSIONS										SCREWS			FEATURES				WEIGHT kg
ds mm	d mm	x	D mm	L mm	L1 mm	L2 mm	L3 mm	lv mm	a x 45° mm	n.	size	Ma Nm	Mt Nm	Fax kN	Ps MPa	Ph MPa	
180													186.000	2.100	236	273	
190	250	x	430	131,5	119,0	53,0	67,0	321	8,0	14	M 20	490	209.000	2.200	239	273	82
200													238.000	2.400	245	273	
190													197.000	2.100	225	262	
200	260	x	430	131,5	119,0	53,0	67,0	321	8,0	14	M 20	490	224.000	2.200	231	262	78
210													254.000	2.400	237	262	
210													260.000	2.500	220	252	
220	280	x	460	144,5	132,0	58,0	76,0	346	9,0	16	M 20	490	292.000	2.700	225	252	97
230													327.000	2.800	230	252	
230													334.000	2.900	219	247	
240	300	x	485	152,5	140,0	63,0	80,0	364	9,0	18	M 20	490	371.000	3.100	224	247	113
250													410.000	3.300	228	247	
240													380.000	3.200	229	257	
250	320	x	520	152,5	140,0	63,0	80,0	386	9,0	20	M 20	490	419.000	3.400	233	257	131
260													457.000	3.500	235	257	
250													465.000	3.700	232	261	
260	340	x	570	168,5	156,0	72,0	88,0	408	9,0	24	M 20	490	506.000	3.900	233	261	186
270													555.000	4.100	237	261	
260													483.000	3.700	217	246	
270	350	x	580	172,5	160,0	73,0	90,0	432	9,0	24	M 20	490	530.000	3.900	220	246	193
280													580.000	4.100	224	246	
280													556.000	4.000	215	239	
290	360	x	590	172,5	160,0	73,0	90,0	432	9,0	24	M 20	490	606.000	4.200	219	239	197
295													632.000	4.300	220	239	
290													682.000	4.700	239	263	
300	380	x	645	179,0	164,0	76,0	92,0	458	9,0	20	M 24	840	739.000	4.900	242	263	255
310													799.000	5.200	245	263	
310													813.000	5.200	249	269	
315	390	x	660	179,0	164,0	76,0	94,5	468	11,0	21	M 24	840	844.000	5.400	251	269	266
320													871.000	5.400	251	269	
315													806.000	5.100	210	231	
320	400	x	680	199,0	184,0	84,0	104,5	480	11,0	21	M 24	840	831.000	5.200	210	231	314
330													896.000	5.400	213	231	
330													967.000	5.900	230	251	
340	420	x	690	199,0	184,0	84,0	104,5	504	11,0	24	M 24	840	1.040.000	6.100	232	251	311
350													1.110.000	6.400	235	251	
340													970.000	5.700	207	229	
350	440	x	750	207,0	192,0	86,0	108,5	527	11,0	24	M 24	840	1.040.000	5.900	209	229	392
360													1.110.000	6.200	212	229	
360													1.040.000	5.800	199	219	
370	460	x	770	207,0	192,0	86,0	108,5	547	11,0	24	M 24	840	1.120.000	6.000	201	219	405
380													1.190.000	6.300	203	219	
380													1.420.000	7.500	221	240	
390	480	x	800	228,0	213,0	96,0	121,5	570	14,0	30	M 24	840	1.510.000	7.700	224	240	485
400													1.600.000	8.000	225	240	
400													1.620.000	8.100	228	245	
410	500	x	850	230,0	213,0	96,0	121,5	590	14,0	24	M 27	1.250	1.700.000	8.300	229	245	560
420													1.800.000	8.600	231	245	

Code:

Ma: screws tightening torque
 Mt: transmissible torque with Fax=0 kN
 Fax: transmissible axial load with Mt=0 Nm
 Ps: contact pressure on shaft
 Ph: contact pressure on hub outer diameter

web clearance Holes (diameter in mm)									
SCREWS size	M5	M6	M8	M10	M12	M16	M20	M24	M27
split shrink disc	7	8	10	13	15	19	23	27	30
shrink disc HALF HT	6	7	9	11	13	18	22	26	30