

MAV 2008

MAV 2108

MAV 2208

Standard Series

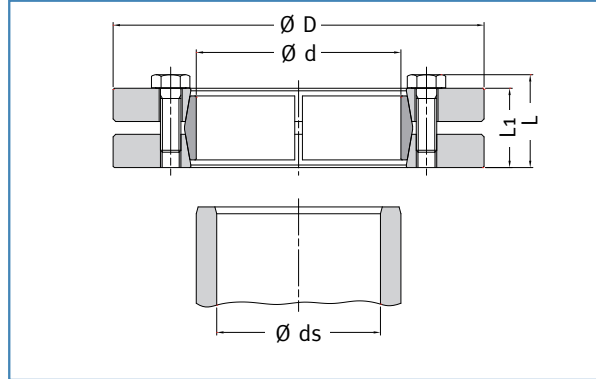
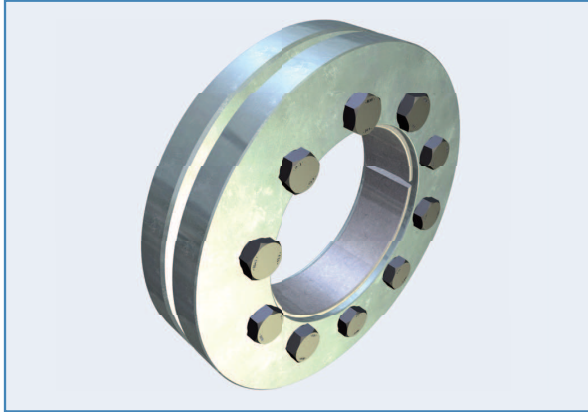

Example of order: MAV 2008 68 x 115

Composition

- Slotted inner ring
- Front outer ring
- Rear outer ring
- Set of hexagonal head cap screws, grade 10.9 (size < M6 of grade 8.8)

Features

- External locking device for hollow shaft (hub) - shaft connection
- Three-part design
- Self-releasing tapers, greased with MoS₂ ($\mu = 0.05$)
- Screws greased with MoS₂ ($\mu = 0.10$)
- Zinc plated outer rings
- O-Ring between outer rings from size $d = 140$ mm and above
- MAV 2008: standard series, medium capacity
- MAV 2108: light series, low capacity
- MAV 2208: heavy series, high capacity
- SPLIT and HALF HC and HT versions also available (for HALF versions, performances are reduced of 50%)
- Tolerances of shaft and hub bore: see table
- Tolerance of hub outer diameter: h8
- Surface finish of shaft and hub $Ra < 3.2 \mu\text{m}$
- Shaft - hub bore contact surface grease-free and dry ($\mu = 0.15$)

Shaft Diameter ds		ISO Tollerances	Max Clearance
from	to		
6	10	H6 - j6	0,011
11	18		0,014
19	30		0,017
31	50	H6 - h6	0,032
51	80	H6 - g6	0,048
81	120	H7 - g6	0,069
121	180		0,079
181	250		0,09
251	315		0,101
316	400		0,111
401	500		0,123

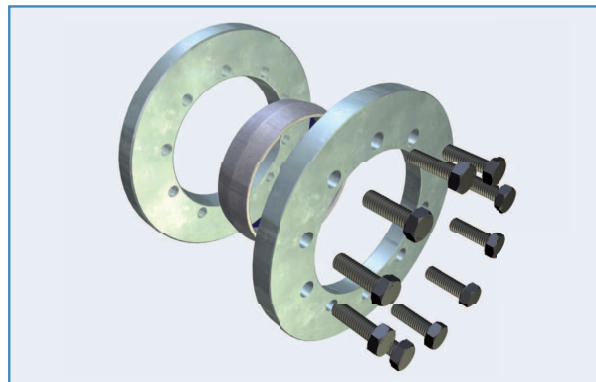

DIMENSIONS										SCREWS			FEATURES				WEIGHT kg
ds mm	d mm	x	D mm	L mm	L1 mm	L2 mm	L3 mm	lv mm	a x 45° mm	n.	size	Ma Nm	Mt Nm	Fax kN	Ps MPa	Ph MPa	
30	40	x	80	37,3	32,0	13,5	18,5	62	2,1	4	M 8	30	1.210	80	229	296	0,9
32													1.320	80	219	296	
34	44	x	85	39,3	34,0	14,5	19,5	66	2,1	5	M 8	30	1.650	100	209	290	1,0
36													2.010	110	227	290	
38	50	x	95	44,3	39,0	16,5	22,0	73	2,1	7	M 8	30	2.750	140	269	345	1,4
40													3.210	160	283	345	
42	55	x	105	44,3	39,0	16,5	22,0	78	2,1	7	M 8	30	3.070	150	246	313	1,7
44													3.530	160	258	313	
46	62	x	115	44,3	39,0	16,5	22,0	85	2,1	7	M 8	30	3.160	140	211	278	2,0
48													3.600	150	221	278	
50	68	x	120	44,3	39,0	16,5	22,0	92	2,9	8	M 8	30	4.010	160	227	290	2,0
52													4.140	160	216	290	
55	75	x	145	52,4	46,0	20,0	25,5	105	2,9	7	M 10	59	5.680	210	221	299	3,8
58													6.700	230	235	299	
60	80	x	145	52,4	46,0	20,0	25,5	105	2,9	7	M 10	59	6.500	220	213	280	3,7
63													7.560	240	225	280	
65	90	x	160	56,4	50,0	22,0	30,0	116	3,7	8	M 10	59	7.500	230	188	256	4,9
68													8.630	250	198	256	
70	100	x	170	60,4	54,0	24,0	32,0	126	4,0	10	M 10	59	7.890	240	180	262	5,7
75													9.900	280	195	262	
75													12.100	320	208	262	7,2
80	110	x	185	66,4	60,0	26,0	35,0	138	4,0	12	M 10	59	12.300	330	186	251	
85													14.900	370	197	251	11
85													16.400	390	193	251	
90	125	x	215	73,5	66,0	28,0	38,0	160	6,0	12	M 12	100	20.100	470	219	297	13
95													23.800	530	231	297	
95													27.800	590	242	297	20
100	140	x	230	81,5	74,0	32,0	42,0	175	6,0	12	M 12	100	21.500	450	169	239	
105													25.200	500	178	239	27
105													29.200	560	187	239	
110	155	x	263	87,5	80,0	35,0	45,0	198	6,0	15	M 12	100	31.100	590	182	245	27
115													35.600	650	189	245	
115													40.500	700	197	245	28
120	165	x	290	98,0	88,0	38,0	49,0	210	6,0	10	M 16	250	48.300	840	215	270	
125													54.200	900	222	270	46
125													59.200	950	223	270	
130	175	x	300	98,0	88,0	38,0	49,0	220	6,0	10	M 16	250	53.200	850	201	255	51
135													59.400	910	207	255	
135													66.000	980	213	255	51
140	185	x	330	122,0	112,0	50,0	61,0	236	6,0	15	M 16	250	92.900	1.400	235	283	
145													102.000	1.500	241	283	51
145													112.000	1.500	246	283	
150	195	x	350	122,0	112,0	50,0	63,5	246	8,0	15	M 16	250	103.000	1.400	226	268	66
155													113.000	1.500	231	268	
145													123.000	1.600	236	268	66
150	200	x	350	122,0	112,0	50,0	63,5	246	8,0	15	M 16	250	99.000	1.400	217	262	
155													108.000	1.400	221	262	86
160													118.000	1.500	226	262	
165	220	x	370	144,0	134,0	60,0	74,5	270	8,0	20	M 16	250	148.000	1.900	215	256	86
170													160.000	1.900	219	256	
170													173.000	2.000	223	256	105
180	240	x	405	157,0	144,0	65,0	79,5	295	8,0	15	M 20	490	181.000	2.100	221	261	
190													205.000	2.300	224	261	105
190													236.000	2.500	231	261	
200	260	x	430	173,0	160,0	72,0	87,5	321	8,0	18	M 20	490	252.000	2.700	218	255	129
210													287.000	2.900	224	255	
210													325.000	3.100	230	255	129
220	280	x	460	185,0	172,0	78,0	96,0	346	9,0	20	M 20	490	323.000	3.100	210	242	
230													364.000	3.300	215	242	
													407.000	3.500	220	242	

MAV 2208

Heavy Series

DIMENSIONS										SCREWS			FEATURES				WEIGHT kg
ds mm	d mm	x	D mm	L mm	L1 mm	L2 mm	L3 mm	lv mm	a x 45° mm	n.	size	Ma Nm	Mt Nm	Fax kN	Ps MPa	Ph MPa	
230	300	x	485	189,0	176,0	80,0	98,0	364	9,0	20	M 20	490	365.000	3.200	193	220	144
240													406.000	3.400	197	220	
245													428.000	3.500	199	220	
240	320	x	520	197,0	184,0	84,0	102,0	386	9,0	24	M 20	490	450.000	3.700	207	235	174
250													492.000	3.900	209	235	
260													543.000	4.200	213	235	
250	340	x	570	215,0	200,0	92,0	110,0	420	9,0	20	M 24	840	544.000	4.400	210	241	237
260													600.000	4.600	214	241	
270													659.000	4.900	218	241	
270	350	x	580	215,0	200,0	92,0	110,0	425	9,0	21	M 24	840	667.000	4.900	221	246	242
280													729.000	5.200	224	246	
290													794.000	5.500	228	246	
280	360	x	590	219,0	204,0	92,0	114,5	432	11,0	20	M 24	840	661.000	4.700	199	223	248
290													721.000	5.000	202	223	
295													753.000	5.100	204	223	
300	390	x	660	227,0	212,0	96,0	118,5	468	11,0	24	M 24	840	850.000	5.700	213	236	335
310													920.000	5.900	216	236	
320													986.000	6.200	217	236	
330	420	x	690	253,0	238,0	109,0	131,5	504	11,0	30	M 24	840	1.210.000	7.300	220	241	400
340													1.300.000	7.600	222	241	
350													1.390.000	7.900	225	241	
360	460	x	770	269,0	252,0	116,0	141,0	547	14,0	28	M 27	1.250	1.650.000	9.100	241	261	540
370													1.760.000	9.500	243	261	
380													1.870.000	9.800	245	261	
380	500	x	850	291,0	274,0	127,0	152,0	590	14,0	32	M 27	1.250	1.890.000	10.000	226	250	750
390													2.010.000	10.000	229	250	
400													2.140.000	11.000	231	250	

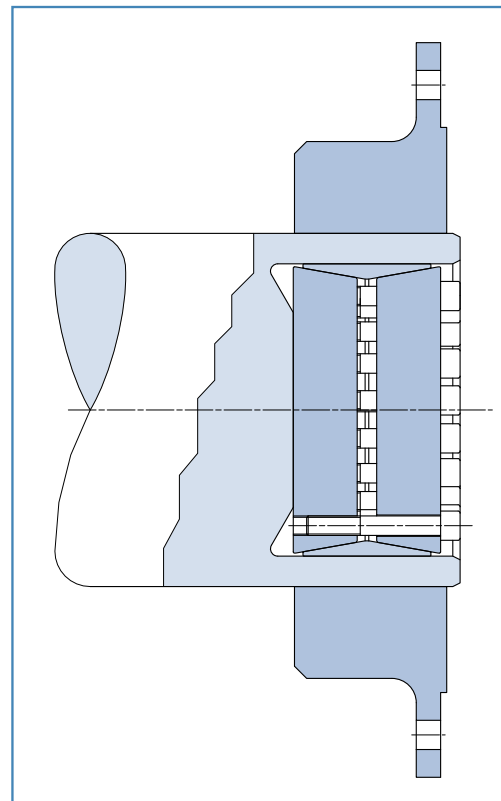
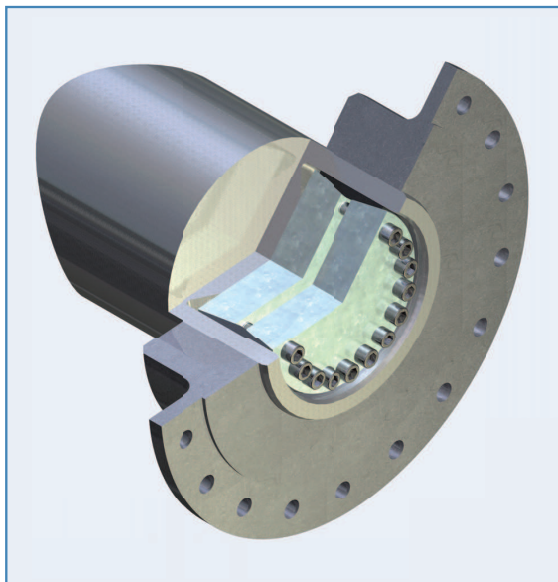

Code:

Ma: screws tightening torque
 Mt: transmissible torque with Fax=0 kN
 Fax: transmissible axial load with Mt=0 Nm
 Ps: contact pressure on shaft
 Ph: contact pressure on hub outer diameter