

PULLEYS, SPROCKETS, TENSIONERS & BEARINGS

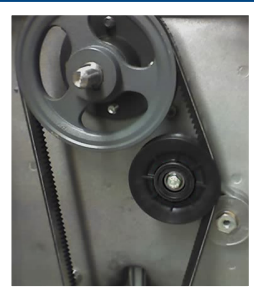

Fenner Drives

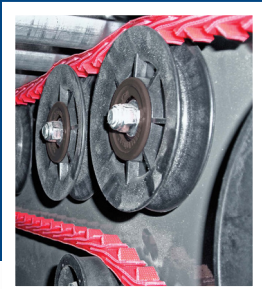

Our Molded Portfolio

Our molded, composite portfolio includes essential products such as Fenner Drives tensioners, pulleys & idlers and Bearings pillow blocks, thrust bearings, radial bearings, washers, and retainers.

These products cover a wide range of markets including:

- Automotive
- Data Centers
- Distribution Centers
- Livestock Farming
- Fitness
- Glass
- Gypsum
- HVAC
- Meat Processing
- Packaging
- Power Tools
- Tile
- Wood Processing

And many others.

While we have an extensive inventory of in stock parts, our engineering team specializes in developing custom designs to fit your application needs. Contact Engineering at 1-800-243-3374.

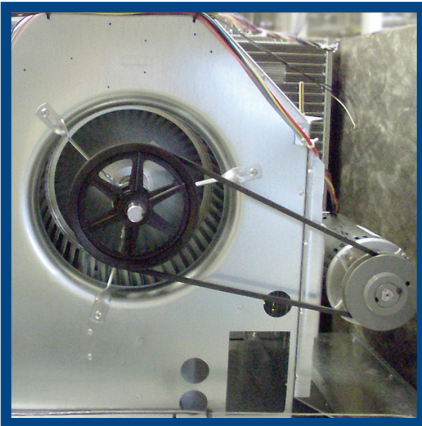
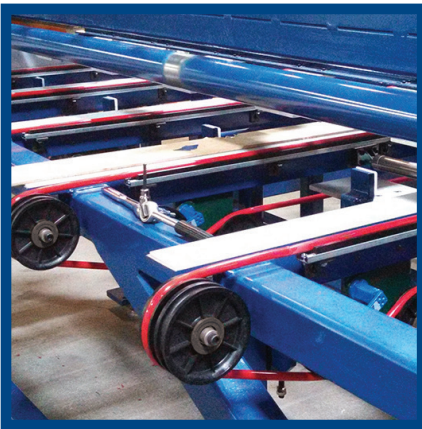

INDEX

Tensioners	4
Rotary Belt and Chain Tensioners	5-6
Linear Chain Tensioners	7
Tensioners, Pulleys and Sprockets Assemblies	8
Pulleys	9
Engineering Data	10
Belt Pulleys and Idlers	11-13
Carriage Roller and Sprockets	14
Pulleys and Mounting Adapters	15
Bearings	16
Pillow Blocks and Flange Bearings	17
Custom Bearings	18-19



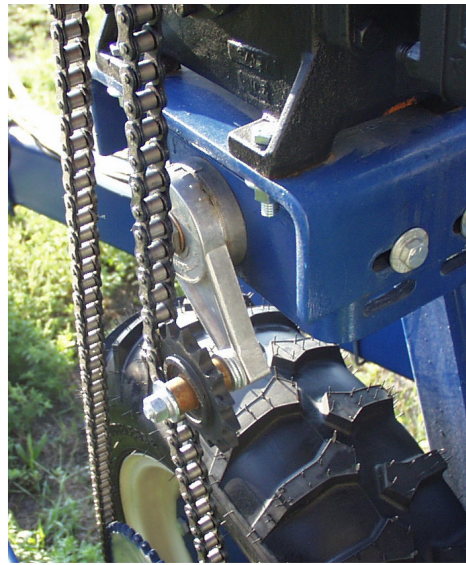

Fenner Drives

Fenner Drives Belt & Chain Tensioners

Automatically take up the slack and avoid the risk of over-tensioning drive components to enhance overall drive operating efficiency.

- Constructed from high-quality materials for proven durability
- Wide range of tensioners to handle single and multiple strand belt and chain drives
- Available in linear and rotary (light-duty, medium and heavy-duty) series
- A range of sizes and mounting styles available to best fit your application

Fenner Drives has proven success in these Markets:

- Data Centers
- Distribution Centers
- Livestock Farming
- Glass
- Gypsum
- HVAC
- Meat Processing
- Packaging
- Wood Processing



RT1000 Series *

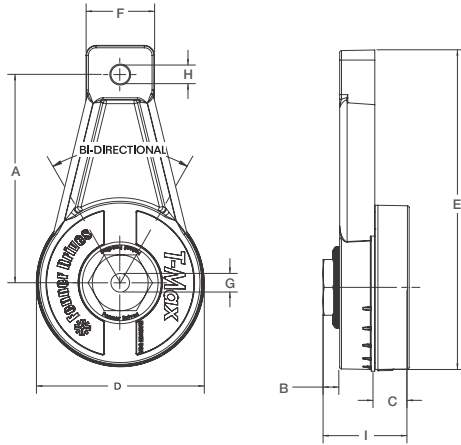

Part Number	Dimensions (inches)									Rotation (degrees)	Force ‡ (lbs)		
	A	B	C	D	E	F	G	H	I				
RT1001	3.50	0.29	0.59	2.76	5.37	1.15	3/8-16	3/8-16	1.45	15	16		
										30	23		
										45	30		
RT1003	3.50	0.29	0.59	2.76	5.37	1.15	0.40	3/8-16	1.45	15	16		
										30	23		
										45	30		
RT1054ZF	3.50	0.29	0.59	2.76	5.37	1.15	3/8-16	3/8-16	1.45	15	16		
										Zerk fitted to apply grease to the spring cavity.		30	23
										45	30		
RT1056ZF	3.50	0.29	0.59	2.76	5.37	1.15	3/8-16	3/8-16	1.45	15	16		
										Zerk fitted to apply grease to the shaft area.		30	23
										45	30		

RT1600 Series *

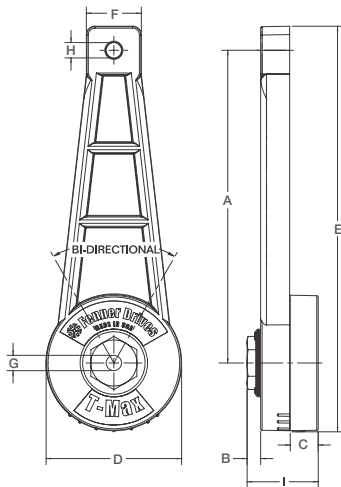

Part Number	Dimensions (inches)									Rotation (degrees)	Force ‡ (lbs)
	A	B	C	D	E	F	G	H	I		
RT1601-L	6.37	0.29	0.59	2.76	8.24	1.12	3/8-16	3/8-16	1.45	15	10
										30	13
										45	16
RT1603-L	6.37	0.29	0.59	2.76	8.24	1.12	0.40	3/8-16	1.45	15	10
										30	13
										45	16
RT1601	6.37	0.29	0.59	2.76	8.24	1.12	3/8-16	3/8-16	1.45	15	20
										25	23
										35	26
RT1603	6.37	0.29	0.59	2.76	8.24	1.12	0.40	3/8-16	1.45	15	20
										25	23
										35	26

RT3000 Series *

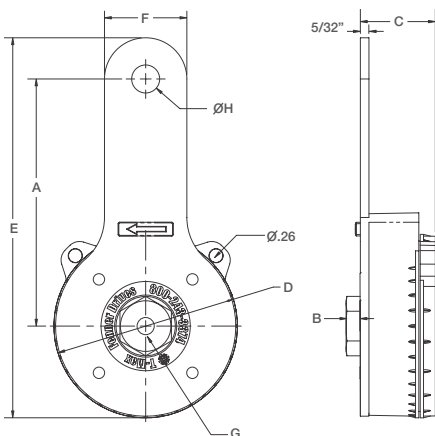

Part Number	Dimensions (inches)								Rotation (degrees)	Force ‡ (lbs)
	A	B	C	D	E	F	G	H		
RT3000	4.50	0.28	1.35	3.34	6.92	1.50	3/8-16	0.51	0 - 70	0 - 42
RT3001	4.50	0.28	1.35	3.34	6.92	1.50	0.40	0.51	0 - 70	0 - 42

* Consult factory for minimum orders and lead times

RT4100 Series *†

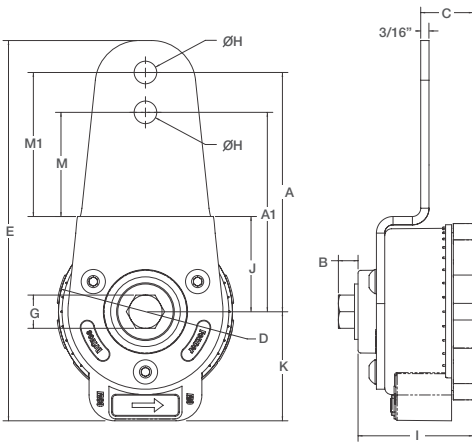

Part Number	Dimensions (inches)													Rotation (degrees)	Force ‡ (lbs)
	A	A1	B	C	D	E	G	H	I	J	K	M	M1		
RT4100	5.40	4.50	0.47	1.19	4.00	8.58	1/2 - 13	0.51	2.60	2.15	2.46	2.35	3.25	0 - 85	0 - 85
RT4101	5.40	4.50	N/A	1.19	4.00	8.58	0.51	0.51	2.60	2.15	2.46	2.35	3.25	0 - 85	0 - 85

RT4900 Series *†

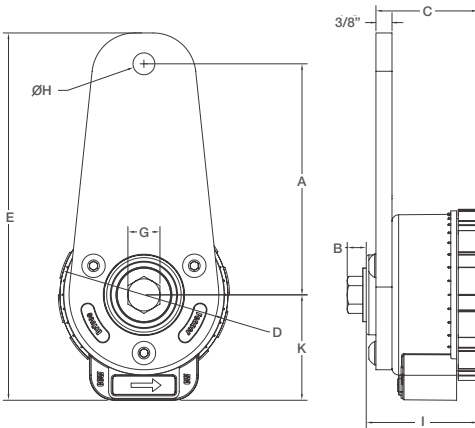

Part Number	Dimensions (inches)										Rotation § (degrees)	Force § (lbs)
	A	B	C	D	E	G	H	I	K			
RT4900	5.40	N/A	2.37	4.00	8.58	0.51	0.51	2.60	2.46	0 - 85	0 - 70	
RT4902	5.40	0.47	2.37	4.00	8.58	1/2 - 13	0.51	2.60	2.46	0 - 85	0 - 70	

- * Maximum load no more than 1½" distance from front face of tensioner arm to centerline of idler.
- † Requires a fixed head, hook style spanner wrench for tensioning (supplied with unit).
- ‡ Dimension A: 1° rotation = .83 lb. force.
- ‡ Dimension A1: 1° rotation = 1 lb. force. All forces (lbs.) are nominal.
- § 1° rotation = .83 lb. force. All forces (lbs.) are nominal.

TMAX TENSIONER BRACKET



Part Number	Bracket Compatible with	Base Compatible with
B1265	RT1000 RT3000	NEMA 48, 56, 143T IEC 63, 71, 80, 90s

* Consult factory for minimum orders and lead times

CT Series: CT1100, CT2100 & CT3100†

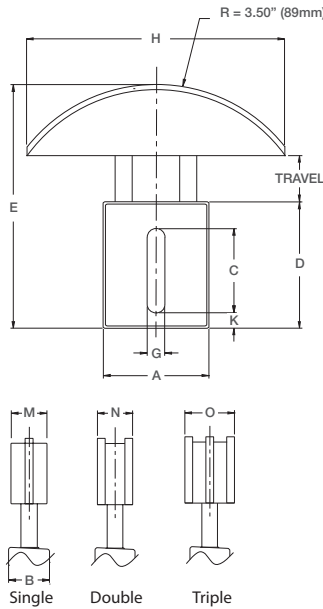

Series	Tensioner Body Dimensions*								Travel (in)	Force † (lbs)
	A	B	C	D	E	G	H	K		
INCH										
CT11XX	2.31	0.98	1.82	2.91	5.6	0.41	5.5	0.46	1.05	15 - 40
CT21XX	2.95	1.18	2.27	3.52	6.4	0.49	5.5	0.45	1.20	20 - 60
CT31XX	3.54	1.35	2.91	4.25	7.5	0.53	5.5	0.49	1.50	45 - 100

Single Chain			Double Chain			Triple Chain			Travel (in)	Force (lbs)
Part Number	Chain	M*	Part Number	Chain	N*	Part Number	Chain	O*		
INCH										
CT1101-L	#35	0.79	CT1103-L	#35	0.79	CT1105-L	#35	0.98	1.05	5 - 30
CT1101	#35	0.79	CT1103	#35	0.79	CT1105	#35	0.98	1.05	15 - 40
CT1102	#40	0.79	CT1104	#40	0.79	CT1106	#40	1.37	1.05	15 - 40
CT2101	#50	0.87	CT2103	#50	0.98	CT2105	#50	1.75	1.20	20 - 60
CT2102	#60	0.87	CT2104	#60	1.37				1.20	20 - 60
CT3101	#80	0.98	CT3103	#80	1.75				1.50	45 - 100
CT3102	#100	0.98							1.50	45 - 100
CT3102-H	#100	0.98							1.00	30 - 200
CT3196	#81X	2.15							1.50	45 - 100
METRIC										
CT1111-L	06B	20	CT1113-L	06B	20				27	22 - 133
CT1111	06B	20	CT1113	06B	20				27	67 - 178
CT1112	08B	20	CT1114	08B	20				27	67 - 178
CT2111	10B	22	CT2112	10B	25				31	89 - 267
CT2109	12B	22							31	89 - 267
CT3111	16B	25	CT3113	16B	44				38	200 - 445
CT3112	20B	25							38	200 - 445
CT3112-H	20B	25							25	134 - 890

CT Series: CT1200, CT2200 & CT3200†

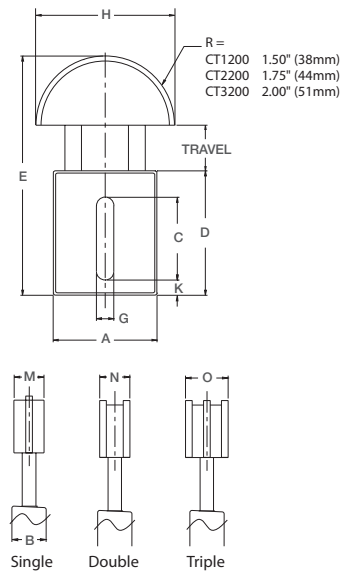

Series	Tensioner Body Dimensions*								Travel (in)	Force (lbs)
	A	B	C	D	E	G	H	K		
INCH										
CT12XX	2.31	0.98	1.82	2.91	5.47	0.41	3	0.46	1.05	15 - 40
CT22XX	2.95	1.18	2.27	3.52	6.47	0.49	3.5	0.45	1.20	20 - 60

Single Chain			Double Chain			Triple Chain			Travel (in)	Force (lbs)
Part Number	Chain	M*	Part Number	Chain	N*	Part Number	Chain	O*		
INCH										
CT1201-L	#35	1.00	CT1203-L	#35	0.79	CT1205-L	#35	0.98	1.05	5 - 30
CT1201	#35	1.00	CT1203	#35	0.79	CT1205	#35	0.98	1.05	15 - 40
CT1202	#40	1.00	CT1204	#40	0.79	CT1206	#40	1.37	1.05	15 - 40
CT2201	#50	1.00	CT2203	#50	0.98	CT2205	#50	1.75	1.20	20 - 60
CT2202	#60	1.00	CT2204	#60	1.37				1.20	20 - 60
CT3201	#80	0.98	CT3203	#80	1.75				1.50	45 - 100
CT3202	#100	0.98							1.50	45 - 100
CT3202-H	#100	0.98							1.00	30 - 200
METRIC										
CT1211-L	06B	20	CT1213-L	06B	20				27	22 - 133
CT1211	06B	20	CT1213	06B	20				27	67 - 178
CT1212	08B	20	CT1214	08B	20				27	67 - 178
CT2208	10B	22	CT2209	10B	25				31	89 - 267
CT2206	12B	22	CT2207	12B	35				31	89 - 267
CT3211	16B	25	CT3213	16B	44				38	200 - 445
CT3212	20B	25							38	200 - 445
CT3212-H	20B	25							25	134 - 890

* Inch dimensions are in inches; metric dimensions are in millimeters.
 † These tensioners can be used on chain sizes up to ANSI #160 or BS/DIN #24B.
 Contact Fenner Industrial Motion Applications Engineering group at AE@fenner.com for head dimensions.
 ‡ All forces are nominal.

Consult factory for minimum orders and lead times

Fenner Drives Tensioner/Pulley Assembly



Assembly Part Number	Component	Component Part Number	
A Section Belt			
FS0578	Tensioner	RT1001	Force Range: 0-30 lb
	Pulley	VA3001	3" OD
FS0581ZF	Tensioner	RT1001	Force Range: 0-30 lb Zerk fitted to apply grease to the spring cavity.
	Pulley	VA3001	3" OD
FS0667ZF	Tensioner	RT1001-L	Force Range: 0-30 lb Zerk fitted to apply grease to the shaft area.
	Pulley	VX3012	3" OD
FS0524	Tensioner	RT3001	Force Range: 0-42 lb
	Pulley	VA3001	3" OD

Fenner Drives Tensioner/Pulley Assembly



Assembly Part Number	Component	Component Part Number	
B Section Belt			
FS0566	Tensioner	RT3001	Force Range: 0-42 lb
	Pulley	VA5001	5" OD
FS0608	Tensioner	RT3000	Force Range: 0-42 lb
	Pulley	VX0285	4" OD Double Groove

Fenner Drives Tensioner/Sprocket Assemblies

Assembly Part Number	Component	Component Part Number	Rotation (Degrees)	Force (lbs)
#35 Chain				
FS0142	Tensioner Sprocket	RT1001 CS3502	15	16
			30	23
			45	30
FS0658	Tensioner Sprocket	RT1601-L CS3502	15	10
			30	13
			45	16
#40 Chain				
FS0651	Tensioner Sprocket	RT1001 CS4002	15	16
			30	23
			45	30
FS0652	Tensioner Sprocket	RT1601 CS4002	15	20
			25	23
			35	26
FS0644	Tensioner Sprocket	RT1601-L CS4002	15	10
			30	13
			45	16
FS0557	Tensioner Sprocket	RT3001 CS4002	0 - 70	0 - 42

Assembly Part Number	Component	Component Part Number	Rotation (Degrees)	Force (lbs)
#50 Chain				
FS0653	Tensioner Sprocket	RT1001 CS5002	15	16
			30	23
			45	30
FS0654	Tensioner Sprocket	RT1601 CS5002	15	20
			25	23
			35	26
FS0659	Tensioner Sprocket	RT1601-L CS5002	15	10
			30	13
			45	16
FS0567	Tensioner Sprocket	RT3001 CS5002	0 - 70	0 - 42
#60 Chain				
FS0655	Tensioner Sprocket	RT1001 CS6002	15	16
			30	23
			45	30
FS0656	Tensioner Sprocket	RT1601 CS6002	15	20
			25	23
			35	26
FS0568	Tensioner Sprocket	RT3001 CS6002	0 - 70	0 - 42
#80 Chain				
FS0657	Tensioner Sprocket	RT1001 CS8002	15	16
			30	23
			45	30



Fenner Industrial Motion has several tensioner/sprocket assemblies not shown here. Contact us for availability.

* Consult factory for minimum orders and lead times



Fenner Drives

Fenner Drives Pulleys, Sprockets and Idlers

Fenner Industrial Motion is the industry leader in molded composite solutions for industrial power transmission and material handling applications. Fenner Drives composite products are used where dependability counts most.

- High-strength glass reinforced composite idlers and pulleys are available in a wide range of sizes for flat, round and V-belts.
- Our composite products are a lightweight, corrosion resistant alternative to steel, aluminum and cast iron.

Fenner Drives has a strong history in the following Markets:

- Data Centers
- Distribution Centers
- Livestock Farming
- Fitness
- HVAC
- Packaging
- Tile



Fenner Drives Engineering Data

Almost all Fenner Drives Pulleys use precision 6203-2RS chrome-alloy steel radial ball bearings (exceptions are noted). These bearings meet all ABEC-1 standards. Our bearings utilize two rubber wiping seals to keep the grease in and contaminants out. See chart for standard load ratings.

Bearing Properties	
Type	6203-2RS
Seals	Rubber Wiping
Fit	ABEC-1 "C4" Internal Clearance
Lubrication	Mobil Polyrex EM or equivalent NLGI No. 2 (30% +/- 5% Fill)
Service Temperature	-20° – 350°F (-30° – 180°C)
Basic Dynamic Load	2150 lbs. (9563N)

6203 Radial Load Ratings											
Speed (RPM)	33	100	200	300	500	1000	1500	1800	2500	3600	5000
Load (lbs)	2141	1480	1175	1026	866	687	601	565	507	449	402
Load (N)	9523	6583	5226	4566	3852	3058	2672	2514	2254	1996	1789

Load Ratings based on 500 HR minimum L₁₀ life.

Bearings are also available in stainless steel, with trash seals and shields.

Bearing Life

How long a bearing will last in an application depends on two variables: first, the bearing's physical properties (material, design, method of manufacture); and second, the conditions of operation (load, speed, temperature, lubrication). Although it is not possible to predict the exact life of a bearing, the designer can calculate the "L10 Life" of a bearing. L10 is the life, in hours or revolutions, that 90% of a group of bearings will complete or exceed. The equations for calculating L10 life are:

Material Properties

Fenner Industrial Motion uses engineering composites, which ensure the highest level of performance and consistent strength. Our standard material is 33% glass reinforced nylon 6/6. The combination of high strength, temperature resistance and abrasion resistance makes nylon a versatile engineering thermoplastic.

- Revolutions: $L_{10} = \left(\frac{C}{P}\right)^3 \times 10^6$
- Hours: $L_{10} = \left(\frac{C}{P}\right)^3 \times \frac{16667}{N}$
- Where:
 L₁₀ = Rating Life
 C = Basic Dynamic Capacity
 P = Radial Load in lbs.
 N = Speed in RPM

33% GLASS-REINFORCED NYLON 6/6, dry as molded		
PROPERTY	ASTM CODE	VALUE
Tensile Strength at Break	D638	20,000 psi
Flexural Modulus	D790	1,300,000 psi
Heat Deflection Temp @ 264 psi	D648	480°F (249°C)
Continuous Service Temp. (Min. – Max.)	N/A	32° to 225°F (0° to 107°C)
Izod Impact Strength (notched 1/8")	D256	1.3 to 1.8 ft.-lb/in. of notch

Data listed was generated using molded specimens tested under standard conditions. Many of the mechanical properties can be influenced by processing conditions, environmental factors and the application of stress. Therefore, this data characterizes typical production material, and should not be used either to establish specification limits or alone as the basis for engineering design.

Fenner Drives V Belt Idlers

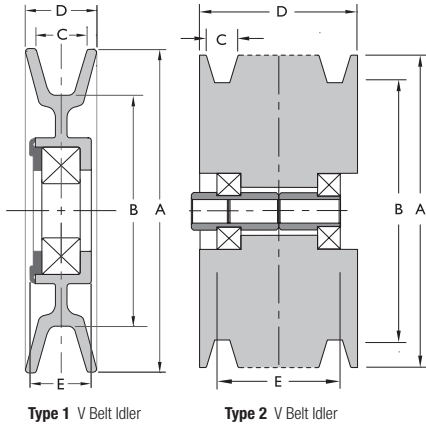

Part Number	Type	Grooves	Dimensions (inches)					Belt Size	Bearing Type	Bore Sizes
			A	B	C	D	E			
VA3001†	1	1	3.0	2.0	0.5	0.7	0.81	A	6203-2RS	17mm
VA3002	1	1	3.0	1.84	0.63	0.78	0.81	B	6203-2RS	17mm
VA4001	1	1	3.98	2.99	0.5	0.7	0.81	A	6203-2RS	17mm
VA4002	1	1	4.0	2.84	0.64	0.86	0.81	B	6203-2RS	17mm
VA5001	1	1	5.04	3.84	0.65	0.8	0.82	B	6203-2RS	17mm
VA6001	1	1	6.03	5.12	0.5	0.72	0.81	A	6203-2RS	17mm
VA6250†	1	1	6.25	5.0	0.61	0.95	0.72	A/B	6203-2RS	17mm
VA7501	1	1	7.5	6.6	0.54	0.72	0.75	A	6203-2RS	17mm
V2B6280	2	2	6.28	5.18	0.64	1.72	1.85	B/5V	6203-2RS	.510/.520
V3B6280	2	3	6.28	5.18	0.64	2.44	2.58	B/5V	6203-2RS	.510/.520
V4B6280	2	4	6.28	5.18	0.64	3.16	3.33	B/5V	6203-2RS	.510/.520

Fenner Drives V Belt Idlers, Single Flange

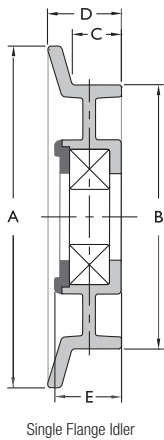

Part Number	Dimensions (inches)					Belt Size	Bearing Type	Bore Sizes
	A	B	C	D	E			
VA3600	3.6	2.84	0.59	0.84	0.8	B	6203-2RS	17mm
VA4130*	4.13	3.23	0.58	0.86	0.81	B	6203-2RS	17mm

Fenner Drives Flat Belt Idlers, Flangeless

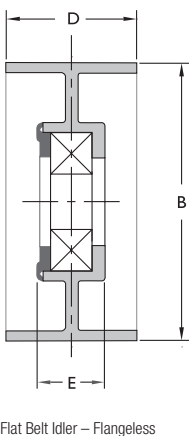

Part Number	Type	Crown	Dimensions (inches)					Belt Size	Bearing Type	Bore Size
			A	B	C	D	E			
FA2009†	1	No	—	2.0	—	1.0	0.47	13/16"	6203-2RS	17mm
FA2010†	1	No	—	1.98	—	0.75	0.47	5/8"	6203-2DD	17mm
FA2700†	1	No	—	2.71	—	1.05	0.67	7/8"	6203-2RS	17mm
FA2900*	1	Yes	—	2.91	—	1.22	0.76	1"	6203-2RS	17mm
FA3003*	1	No	—	2.96	—	1.09	0.76	29/32"	6203-2RS	17mm
FA3250†	1	No	—	3.2	—	1.01	0.67	13/16"	6203-2DD	17mm
FA4502	1	No	—	4.5	—	1.21	0.82	1"	6203-2RS	17mm
FX0002*‡	1	Yes	—	2.33	—	1.39	—	11/8"	6205-2RS	1"

* Consult factory for minimum orders and lead times
 † Insertion molded bearing
 ‡ Special 1" bore bearing with extended inner-race

See pg. 15 for mounting adapters

Fenner Drives Pulleys & Idlers

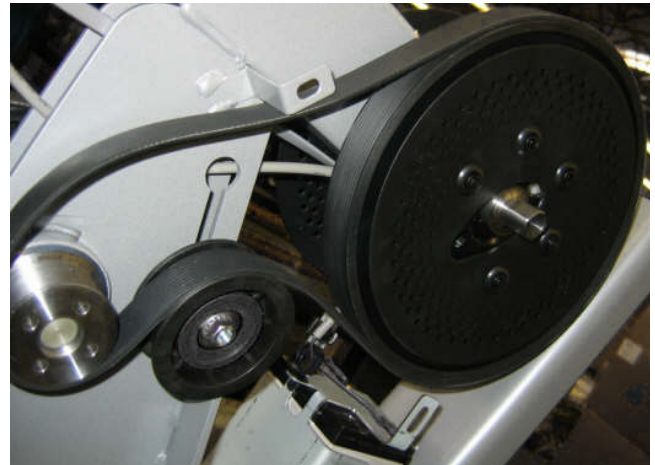
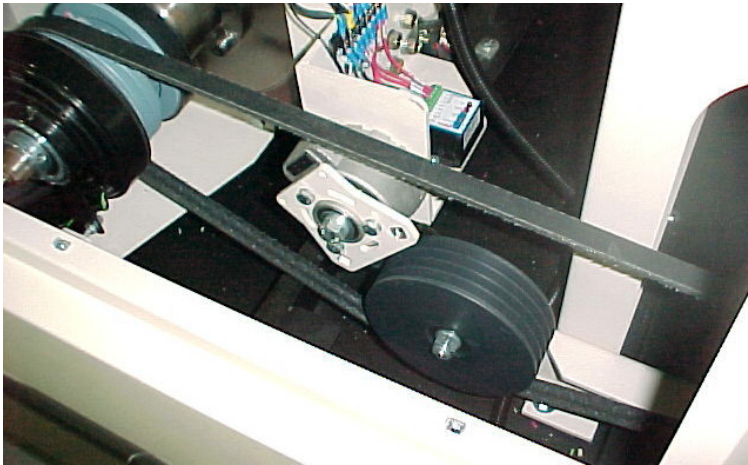

Fenner Drives Flat Belt Idlers, 2 Flange

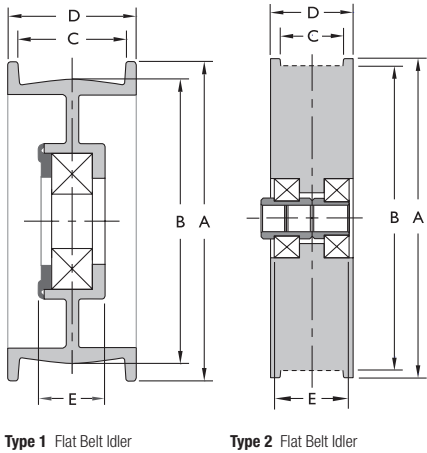

Part Number	Type	Crown	Dimensions (inches)					Belt Size	Bearing Type	Bore Size
			A	B	C	D	E			
FA1870	1	No	1.87	1.53	0.51	0.69	-	1/2"	6202-2RS	15mm
FA2001†	1	Yes	2.07	1.88	1.37	1.54	0.47	1 1/8"	6203-2RS	17mm
FA2002†	1	Yes	2.35	1.99	0.98	1.15	0.47	7/8"	6203-2RS	17mm
FA2003	1	No	2.76	1.94	0.82	1.15	0.75	5/8"	6203-2RS	17mm
FA2501†	1	No	2.48	1.97	1.55	1.85	0.72	11/4"	6203-2RS	17mm
FA2750†	1	Yes	2.75	1.97	1.09	1.4	0.67	29/32"	6203-2RS	17mm
FA2751	1	Yes	2.75	2.52	1	1.22	0.8	13/16"	6203-2RS	17mm
FA3002	1	Yes	3	2.5	1.02	1.31	0.76	7/8"	6203-2RS	17mm
FA3251†	1	Yes	3.24	2.97	1.04	1.2	0.67	7/8"	6203-2DD	17mm
FA3301†	1	Yes	3.38	2.97	1.38	1.67	0.78	11/8"	6203-2RS	17mm
FA3501	1	Yes	3.5	3	0.77	1.09	0.76	5/8"	6203-2RS	17mm
FA3502	1	Yes	3.5	3	1	1.22	0.76	13/16"	6203-2RS	17mm
FA3504	1	Yes	3.48	2.98	0.69	0.9	0.76	1/2"	6203-2RS	17mm
FA3750†	1	Yes	3.75	2.96	1.09	1.38	0.67	29/32"	6203-2RS	17mm
FA3751†	1	Yes	3.8	3.25	1.03	1.24	0.67	7/8"	6203-2RS	17mm
FA4501	1	Yes	4.5	4	1.09	1.39	0.76	29/32"	6203-2RS	17mm
FA4750†	1	Yes	4.75	3.96	1.09	1.38	0.67	29/32"	6203-2RS	17mm
FA5501†	1	Yes	5.56	5.03	1.02	1.29	0.72	7/8"	6203-2RS	17mm
FX0001‡	1	Yes	2.75	2.37	1.07	1.39	—	29/32"	6205-2RS	1"
F1B6280	2	No	6.28	6	1.22	1.63	1.63	1"	6203-2RS	.510/.520
F2B6280	2	No	6.28	6	2.1	2.5	2.5	2"	6203-2RS	.510/.520
F3B6280	2	No	6.28	6	2.91	3.31	3.31	2 3/4"	6203-2RS	.510/.520
F4B6280	2	No	6.28	6	3.85	4.25	4.25	3 3/4"	6203-2RS	.510/.520

* Consult factory for minimum orders and lead times

See pg. 15 for mounting adapters

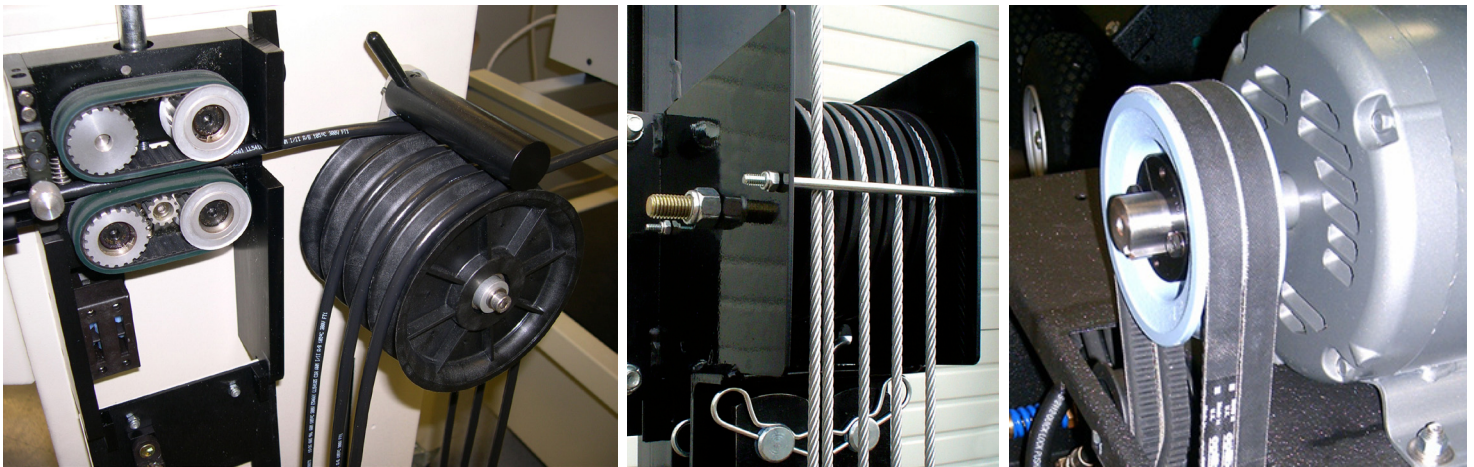

Fenner Drives Round Belt Idlers

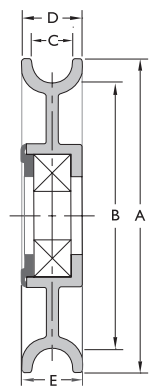

Round Belt Idler

Part Number	Dimensions (inches)					Radius	Maximum Belt Size	Bearing Type	Bore Sizes
	A	B	C	D	E				
RA2130	2.13	1.7	0.34	0.50	0.50	0.17	5/16"	6203-2RS	15mm
RA3001	3.05	2.45	0.4	0.61	0.81	0.19	3/8"	6203-2RS	17mm
RA3002	3.05	2.45	0.42	0.61	0.63	0.21	13/32"	6203-2RS	17mm
RA3501	3.5	2.75	0.53	0.76	0.76	0.26	1/2"	6203-2RS	17mm
RA3502	3.5	2.75	0.44	0.76	0.76	0.19	3/8"	6203-2RS	17mm
RA4101	4.12	3.5	0.53	0.68	0.72	0.26	1/2"	6203-2RS	17mm
RA4801	4.8	4	0.53	1	0.77	0.28	1/2"	6203-2RS	17mm
RA4802	4.82	4	0.73	1.06	0.77	0.36	11/16"	6203-2RS	17mm
RA5502†	5.38	4.62	0.38	0.56	0.7	0.19	3/8"	6203-2RS	17mm
SMALL SERIES									
RA1850†	1.84	1.39	0.4	0.63	0.63	0.16	5/16"	6902-2RS	15mm
RA2540	2.54	1.9	0.44	0.63	0.63	0.16	5/16"	6902-2RS	15mm

Fenner Drives Cable Pulleys

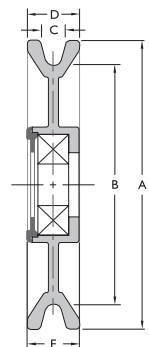

Cable Pulley

Part Number	Dimensions (inches)					Maximum Cable Size	Bearing Type	Bore Size
	A	B	C	D	E			
RA2701	2.75	2.43	0.23	0.54	0.82	5/32"	6203-2RS	17mm
RA3503†	3.55	2.73	0.39	0.8	0.77	1/4"	6203-2RS	17mm
RA3504	3.5	2.81	0.31	0.65	0.77	7/32"	6203-2RS	17mm
RA4501†	4.46	3.74	0.38	0.86	0.77	1/4"	6203-2RS	17mm
RA4502†	4.46	3.74	0.38	0.86	0.77	3/16"	6203-2RS	17mm
RA5001	5	4.31	0.31	0.65	0.73	3/16"	6203-2RS	17mm
RA5501†	5.5	4.86	0.22	0.53	0.6	5/32"	6203-2RS	17mm
RA6001	6	5.2	0.4	0.8	0.8	1/4"	6203-2RS	17mm

* Consult factory for minimum orders and lead times

See pg. 15 for mounting adapters



Fenner Drives Sprockets

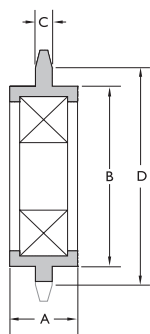

Sprocket

Part Number	Chain #	# Teeth	Nominal O.D. (in)	Pitch Diameter (in)	Dimensions (inches)			Bearing Type	Bore Size
					A	B	C		
CS3502†	35	19	2.48	2.28	0.67	1.78	0.164	6203-2RS	17mm
CS4002†	40	17	2.98	2.72	0.67	1.78	0.279	6203-2RS	17mm
CS4003†	40	17	2.98	2.72	0.67	1.78	0.279	6203-2RS-10	5/8"
CS4006*†	40	17	2.98	2.72	0.67	1.78	0.279	6203-2RS-12	3/4"
CS5002†	50	15	3.34	3.01	0.67	1.78	0.343	6203-2RS	17mm
CS5004†	50	15	3.34	3.01	0.67	1.78	0.343	6203-2RS-10	5/8"
CS5005*†	50	15	3.34	3.01	0.67	1.78	0.343	6203-2RS-12	3/4"
CS6002†	60	13	3.52	3.14	0.67	1.78	0.449	6203-2RS	17mm
CS6003†	60	13	3.52	3.14	0.67	1.78	0.449	6203-2RS-10	5/8"
CS6004†	60	13	3.52	3.14	0.67	1.78	0.449	6203-2RS-12	3/4"
CS8002†	80	12	4.39	3.86	0.67	1.78	0.58	6203-2RS	17mm
CS8003*†	80	12	4.39	3.86	0.67	1.78	0.58	6203-2RS-10	5/8"
CS8004†	80	12	4.39	3.86	0.67	1.78	0.58	6203-2RS-12	3/4"

Fenner Drives Carriage Rollers

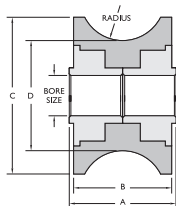

Type 1

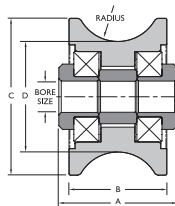

Type 2

Part Number	Type	Dimensions (inches)				Radius	Bore Sizes
		A	B	C	D		
RA2002	1	1.36	1.2	1.95	1.37	0.53"	1/2"
RA2004	1	1.48	1.2	1.95	1.37	0.53"	1/2"
RX0219	2	1.48	1.2	1.95	1.38	0.53"	3/8"

* Consult factory for minimum orders and lead times
 † Insertion molded bearing
 ‡ Special I" bore bearing with extended inner-race

Fenner Drives DriveN Pulleys

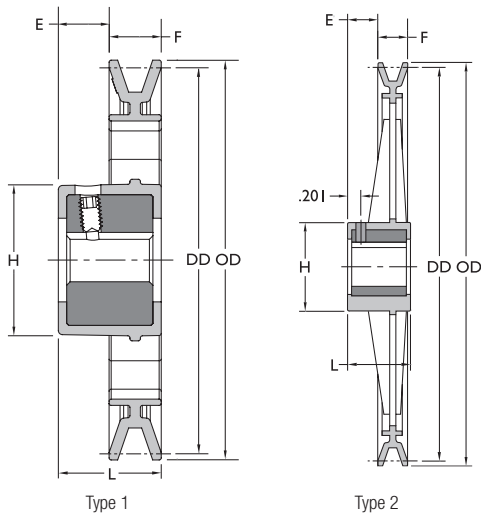

Base Part Number	Dimensions (inches)					Belt Size	Diameter (inches)		Number Spokes	Spoke Style
	Type	E	F	H	L		Outside	Datum		
AFD44*	1	0.79	0.74	2.17	1.53	A/4L	4.25	4	-	-
AFD49	1	0.79	0.74	2.17	1.53	A/4L	4.75	4.5	4	I-Beam
AFD59	1	0.79	0.74	2.17	1.53	A/4L	5.75	5.5	4	I-Beam
AFD74	1	0.79	0.74	2.17	1.53	A/4L	7.25	7	4	I-Beam
AFD84	2	0.76	0.75	2.22	1.6	A/4L	8.25	8	6	Cross
AFD94	2	0.76	0.75	2.22	1.6	A/4L	9.25	9	6	Cross
AFD104	2	0.76	0.75	2.22	1.6	A/4L	10.25	10	6	Cross
AFD112	2	0.76	0.75	2.22	1.6	A/4L	10.98	10.73	6	Cross
AFD124	2	0.76	0.75	2.22	1.6	A/4L	12.25	12	6	I-Beam

Shaft Size	Keyseat
5/8", 3/4"	3/16" x 3/32"
1"	1/4" x 1/8"

Part Number Ordering Guide

Base Part Number	+	Shaft Size	=	Complete Part Number
AFD44		5/8"		AFD4458
AFD94		1"		AFD94100

Many idlers are, or can be, made into a driven pulley with a 5/8" or 3/4" bore. Please contact Fenner Industrial Motion for minimum order quantities, pricing, and availability.

Clevis Adapters

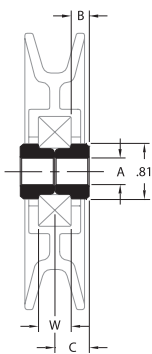

Part Number	Dimensions (inches)			
	A	B	W	C
CB0001	.385 / .395	0.26	0.472	0.5
CB0002	.385 / .395	0.51	0.472	0.75
CB0003	.385 / .395	0.76	0.472	1
CB0004	.510 / .520	0.26	0.472	0.5
CB0005	.510 / .520	0.51	0.472	0.75
CB0006	.510 / .520	0.76	0.472	1
CB0015	.314 / .324	0.08	0.472	0.32
CB0016	.385 / .395	0.17	0.472	0.41
CB0020	.314 / .324	0.1	0.472	0.34
CB0023	.394 / .399	0.64	0.472	0.87
CB0036	.385 / .395	0.7	0.472	0.94
CB0058	.385 / .395	0.33	0.472	0.57
CB0100	.397 / .407	0.26	0.472	0.5

Shoulder Adapters

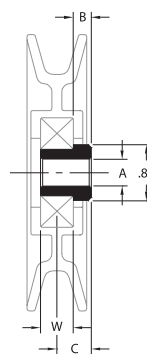

Part Number	Dimensions (inches)			
	A	B	W	C
SB0001	.385 / .395	0.26	0.472	0.5
SB0002	.385 / .395	0.51	0.472	0.75
SB0003	.385 / .395	0.76	0.472	1
SB0004	.510 / .520	0.26	0.472	0.5
SB0005	.510 / .520	0.51	0.472	0.75
SB0006	.510 / .520	0.76	0.472	1
SB0013	.385 / .395	0.15	0.472	0.38
SB0018	.385 / .395	0.4	0.472	0.64
SB0020	.385 / .395	0.59	0.472	0.83
SB0032	.385 / .395	0.56	0.472	0.8
SB0033	.385 / .395	0.95	0.472	1.19
SB0052	.385 / .395	0.71	0.472	0.95
SB0090	.255 / .265	0.31	0.472	0.55

Bore Reducing Adapters

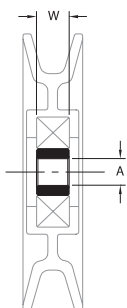

Part Number	Dimensions (inches)	
	A	W
RB0001	.385 / .395	0.472
RB0002	.510 / .520	0.472
RB0071	.474 / .486	0.472

Mounting adapters are for use with PowerMax products and are not sold individually. Consult factory for min orders and lead times.

* Consult factory for minimum orders and lead times
 † Insertion molded bearing
 ‡ Special 1" bore bearing with extended inner-race

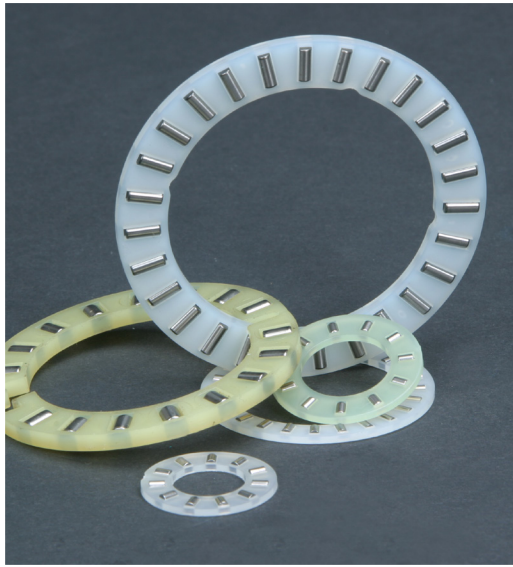

Fenner Drives

Pillow Block Bearings

Composite pillow block bearings designed to perform like metal.

- Benefits of composite in the housing
- Industry standard dimensions
- Custom designs for OEMS available



Custom Bearings

Custom thrust bearings, radial bearings, angular contact bearings, subassemblies and bearing components

- An industry leading brand that is manufactured in the U.S.
- Custom bearings for a range of applications from power tools to transportation that are designed to fit precise space requirements, performance needs, environmental conditions and all quality specifications
- Expertise in CNC machining, injection molding, stamping and assembly to provide subassemblies
- Services to design, manufacture and assemble the right bearing for the specific application

Fenner Drives Bearings products are found in these Markets:

- Appliances
- Automotive
- Fitness
- HVAC
- Medical Devices
- Power Tools and Equipment

Fenner Drives Bearings Pillow Block Bearing

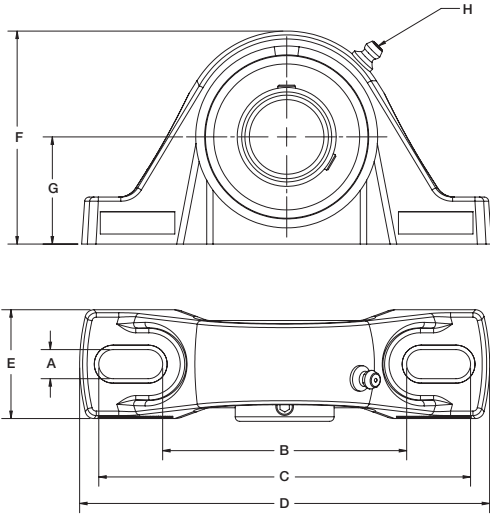

Basic Dynamic Load Rating: 3145 lbf
Static Load Rating: 1750 lbf

Part Number	Dimensions (inches)							Zerk	Bearing Type	Bore Size
	A	B	C	D	E	F	G	H		
PB1000	0.39	3.3	4.9	5.7	1.6	2.8	1.45	No	SB205-16	1"
PB1032	0.51	4.38**	N/A	5.7	1.6	2.8	1.45	No	SB205-16	1"
PB2050	0.39	3.3	4.9	5.5	1.5	2.9	1.44	Yes	SB205-16	1"

NOTE: Also available in the following bore sizes 7/8", 15/16" and 25mm as a non catalog item. Consult factory for minimum orders and lead times

** Dimension (B) is the hole center distance, (A) is the hole diameter

Fenner Drives Bearings Pillow Block Flange Bearings

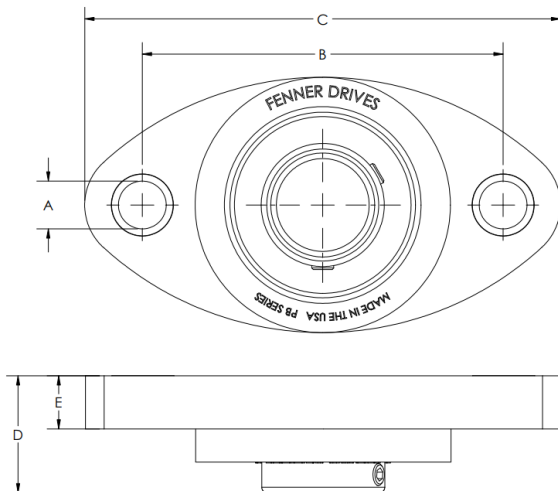

Part Number	Dimensions (inches)					Zerk	Bearing Type	Bore Size
	A	B	C	D	E	H		
PB1007	0.390	3.88	5.12	1.27	0.94	No	SB205-16	1"
PB1035	0.515	3.88	5.12	1.27	0.94	No	SB205-16	1"
PB1041	0.390	3.00	3.97	1.22	0.80	No	SB205-16	1"

NOTE: Consult factory for minimum orders and lead times

Custom Bearing Assemblies

Our custom bearing assemblies are manufactured to meet your application's specific needs. Every feature of a bearing assembly can be customized to maximize the benefit to your product. By working with your engineering department from the start, collaborating throughout the design, prototyping and manufacturing processes and delivering your orders on time, Fenner Drives Bearings can guarantee quality, performance and your satisfaction.



Engineering

Fenner Drives Bearings has an engineering department with decades of experience in bearing and assembly design. Our engineers have designed thousands of bearing assemblies and components in nearly 100 years of manufacturing. We utilize the latest design technologies to develop the right combination of materials, processes and inspection techniques. As a result, we can work with your engineers to design a solution that will provide the ideal bearing assembly for your product.

Manufacturing

Fenner Drives Bearings has a modern and fully integrated manufacturing facility capable of producing customized bearing assemblies and components. We have developed highly flexible and automated systems that enable us to meet any production volume. Our manufacturing capabilities include:

- Metal stamping presses
- Plastic injection and insert molding machines
- Multispindle and CNC screw machines
- Robotic assembly machines
- Finishing, inspection and packaging systems

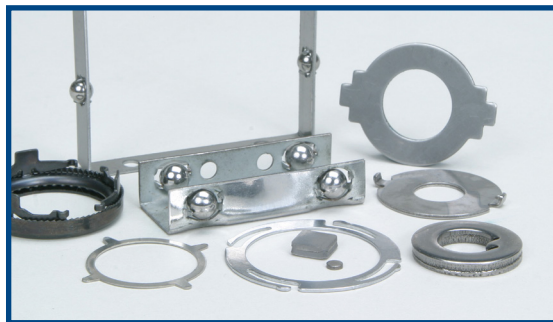
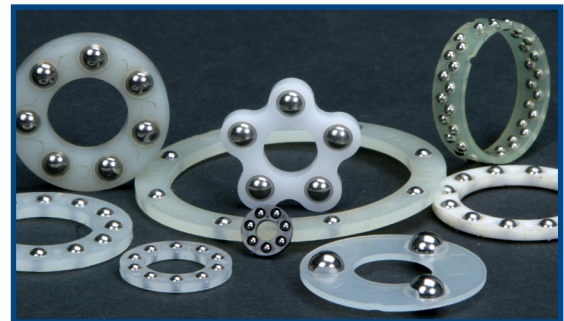

Quality and Dependability

Fenner Drives Bearings maintains a vigorous quality assurance program. Our quality system is ISO 2001:2015 registered. Our product manufacturing teams and support departments are dedicated to ensuring that your bearings are manufactured to your exacting specifications and shipped on time. Our customer service team is focused on providing you with a seamless and efficient buying experience.



Radial Bearings

- Excellent choice for consumer, commercial and light industrial applications
- Unground races in metal, plastic and insert molded combinations
- Infinite range of custom mounting choices

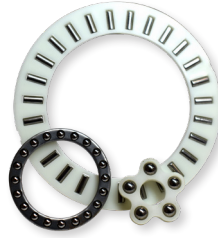

Thrust Retainers

- Perfect for controlling precision ball and needle load distribution
- Retainer materials are selected to meet diverse environmental conditions
- Combine with thrust washers to create the ideal thrust bearing assembly



Angular Contact Bearings

- Ideal in applications requiring combined radial and thrust loads
- Available in machined or stamped metal and injection molded designs
- Customized designs can accommodate additional functional features



Thrust Washers & Thrust Slugs

- Highly effective solution for thrust races, spacers, wear plates and bearing load surfaces
- Application specific hardness and surface finishes ensure reliable performance
- Custom designs accommodate space limitations



Plastic Roller Assemblies

- Preferred choice for light duty guide and track applications
- Rollers designed to meet custom performance requirements with engineered plastics
- Studs may be adapted to accommodate and simplify your assembly processes



Thrust Bearings

- Combines thrust retainers and thrust washers into a single package
- Any combination of metal and engineered plastic components are available
- Significantly improves assembly error proofing



Subassemblies

- Custom engineered subassemblies expand your manufacturing capacity
- Reduces assembly, purchasing and inventory costs
- Reduces quality problems



Linear Retainers

- Perfect solution for linear reciprocal motion applications
- Custom designed to provide ball separation and uniform load distribution
- Simplifies assembly operations



Ribbon Retainers

- Custom designed to provide ball separation and uniform load distribution in precision bearings



Cup and Cone Retainers

- Unique wraparound retainer design for angular contact applications
- One-piece assembly reduces installation time and labor



At Fenner Precision Polymers, A Michelin Group Company, we are proud to keep your business in motion. As a supplier of critical components and engineered solutions for conveying, motion control and power transmission applications, our trusted brands are recognized globally for providing unique solutions that solve complex problems and build sustainable growth. We strive to partner closely with you so we can always provide expert-level support and powerful results that keep our world moving forward.



US and Canada 1-800-243-3374
Latin America 1-717-665-2421
Europe, Asia, Australia and Africa +44 0 870 757 7007

www.fenner.com

© 2025 Fenner Precision Polymers FPP_BR_IM_APC-Moulded_25-09_V1